

ROTO-CLEAN
MODELS 4900-178 & 4900-112



Fraser static control equipment has been designed to give you many years of productive service. However, the science of static control has unique rules which must be followed to allow the equipment to give a good return on your investment. Please read the following operating and maintenance instructions carefully.

Contents

1. The Equipment.....	4
2. Checking the Delivered Equipment	6
3. Safety	6
4. Technical Specifications	7
5. Mounting and Installation.....	8
6. Maintenance	13
7. Troubleshooting.....	14
8. Warranty	15
9. Certification and Declaration of Conformity.....	15
10. Spare Parts	16

1. The Equipment

Models 4900-112 and 4900-178 are high performance static eliminator ring bars fitted with rotating nozzles driven by compressed air for surface cleaning applications. Through rotational movement, they produce an energetic pulsating airflow, which combined with the static eliminator, captures and removes surface contamination.

The 4900-112 has a diameter of 112mm. The 4900-178 has a diameter of 178mm.

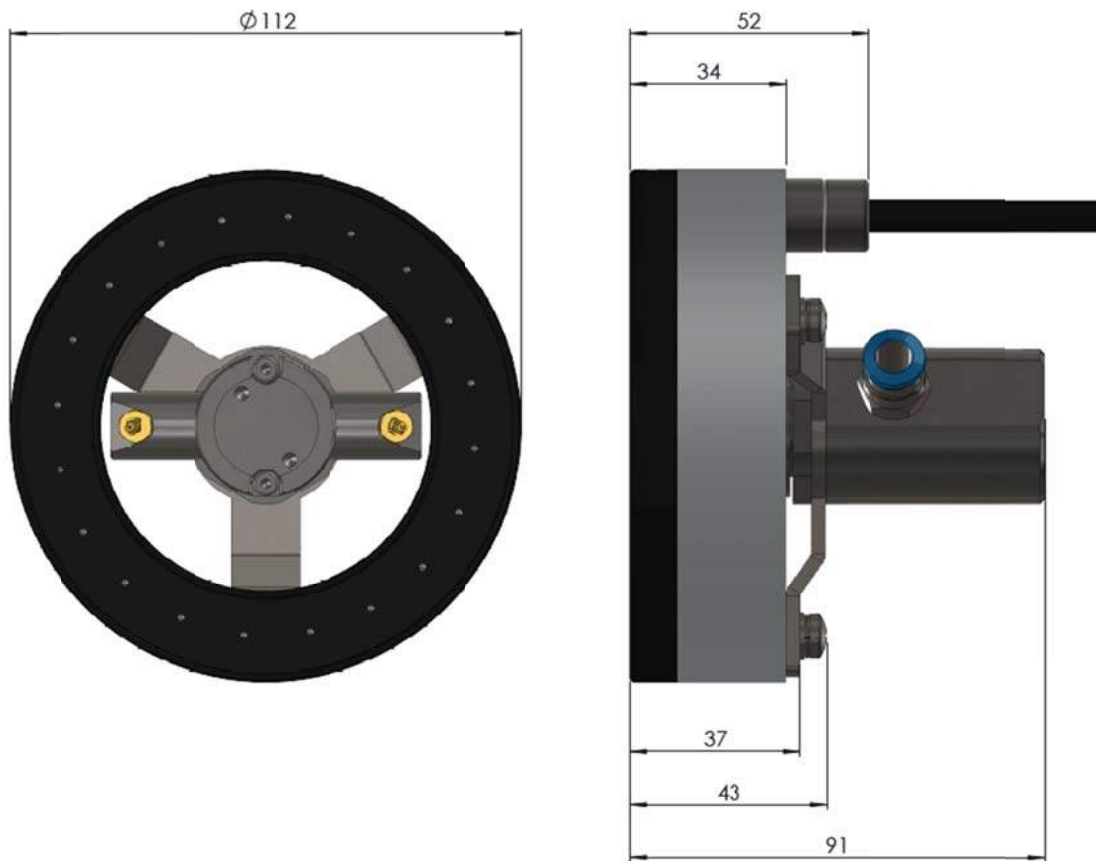

Model: 4900-112 (dimensions in mm)

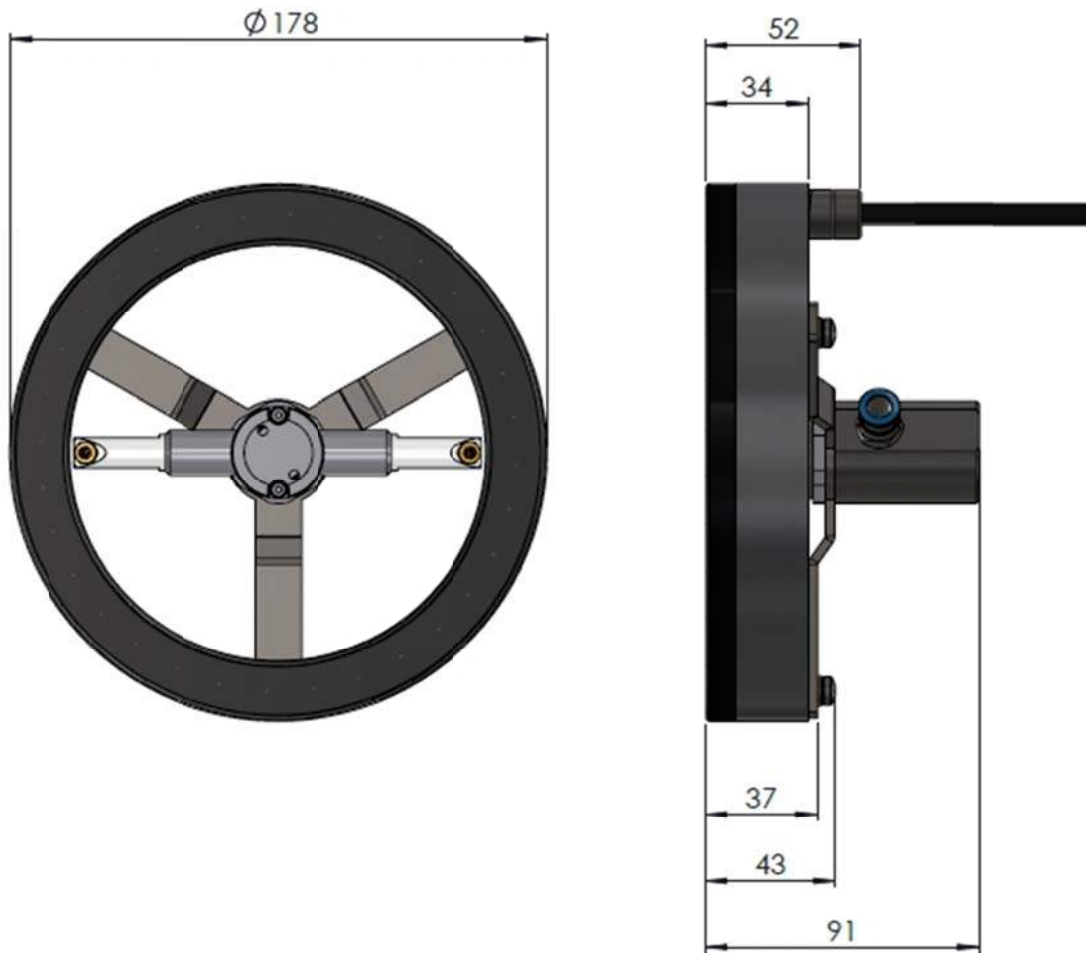

Model: 4900-178 (dimensions in mm)

Both units have a fixed mounting block with a M8 x 15mm mounting hole and a 8mm quick release air inlet fitting.

A Power Unit is required to generate and deliver the high-voltage to the ring bar. It converts mains primary input voltage to high voltage which is transmitted to the Bar by the HV cable. The emitter pins in the ring bar use the high voltage to produce a thick cloud of ionised air dense with positive and negative ions to neutralise static charges.

2. Checking the Delivered Equipment

The equipment leaves our factory in suitable protective packaging. Please check that it is undamaged when it arrives. If there is visible damage contact the factory or one of our distributors immediately, before carrying out any installation.

Check that the parts which have been delivered are the same as you ordered.

3. Safety

Proper Use:

Only intended for internal factory applications.

Must only be used with a suitable Fraser Power Unit.

Not certified for use in hazardous areas. For these areas see Fraser EX certified Bars.

Designed exclusively for operation with oil-free, dry and filtered compressed air conforming to DIN ISO 8573 class 3 or better.

Ambient temperature must not exceed 60°C.

The rotating nozzles units must not come into contact with water or corrosive environments.

Faulty air hoses and connectors can cause serious injury. Only install compressed air hoses when depressurized.

Noise levels must be checked in final installation and operating air pressure.

Operators must wear eye protection if working in the vicinity of an operating rotational nozzle.

Identification of Hazards:

Fraser designs and manufactures this equipment using the latest technology and safety information. However, all high voltage equipment should be treated with care and only installed and maintained by qualified engineers who have read and understood these instructions.

Please pay particular attention to parts of this manual marked with this symbol which indicate potential safety hazards.



4. Technical Specifications

Power Unit:	Use with Fraser 5.5kV or 6kV Power Units										
Air Inlet:	8mm push in, quick fit (Festo)										
Air Pressure:	1.5 - 5.0 BAR MAXIMUM. DO NOT EXCEED THIS LEVEL.										
Air Quality:	Only use oil-free, dry and filtered compressed air conforming to DIN ISO 8573 class 3 or better.										
Air Consumption:	<table border="1"><thead><tr><th>BAR</th><th>l/min</th></tr></thead><tbody><tr><td>1.5</td><td>200</td></tr><tr><td>2.0</td><td>250</td></tr><tr><td>3.5</td><td>400</td></tr><tr><td>5.0</td><td>540</td></tr></tbody></table>	BAR	l/min	1.5	200	2.0	250	3.5	400	5.0	540
BAR	l/min										
1.5	200										
2.0	250										
3.5	400										
5.0	540										
Ring Bar:	Anodised aluminium, FR-ABS, epoxy resin										
Air Parts:	Stainless Steel, Aluminium and Brass (air nozzles)										
HV Cable:	Special screened HT Cable with PVC outer sheath. Nominal diameter 6mm. Bend radius 70mm. Maximum length depends on Power Unit ordered: HP50 and 9055-2, maximum length 12m. HP50-F maximum length is 25m.										
Ring Bar Resistors:	100MOhm resistance between emitter and the HV. This makes the emitters shockless to touch. Note: if the emitters are connected in parallel the resistance is reduced and shocklessness cannot be guaranteed.										
Ambient Conditions:	Maximum temperature 60°C. Minimum temperature 0°C. Maximum humidity 70% RH, non-condensing.										
Nozzle Rotation:	The nozzle RPM is regulated by centrifugal control and designed to be independent of air pressure.										
Nozzle Bearings:	See maintenance. Factory sealed. Not user serviceable.										
Sound Pressure:	High sound pressure levels are generated by the release of compressed gas through air nozzles. Typically 80dBA at 1m at 3.5Bar. Higher levels are possible depending on installation configuration. These levels must be checked for operator safety in application, and appropriate safeguards installed as necessary.										

5. Mounting and Installation

Before installation, check the rotation of the nozzle for any damage during transport or handling. Installation and operation must only be performed by qualified persons observing safety warnings and complying with operator health and safety obligations.

Install only when depressurised!



Positioning

- i) The best location is usually at, or immediately before, the area where static is causing the problem - remember that static can be regenerated if the material passes over rollers or through a process after neutralising. A static meter is useful to determine the best position.
- ii) Important. The material to be neutralised generally should be in free air, not touching another surface as it passes the Bar. It is not possible to neutralise static electricity where the material is touching another surface or roller. Position the bar 50mm from rollers or the machine frame.
- iii) The emitter pins should face the material to be neutralised and be about 25mm from it for best operation. The bar must be dry and oil-free.
- iv) It is important that the emitter pins are not touching, or within 10mm of other metal objects, to avoid spark erosion that will damage both the Bar and the metal object.

Cable

The high voltage flex cable is made to a high specification and must be treated carefully. Sharp bends will damage the insulation and lead to breakdown. It is very important that cable ties are not used to fix the cable (for example to an airpipe) and that the cable is not bent more than 70mm diameter. See sketches below:



No tight bends

able ties can damage the Cable

Min. bend diameter 70mm

Mounting

Securely mount the unit to a stable surface using the M8 x 15mm threaded hole in the base mounting block (34mm diameter with 30mm flats).

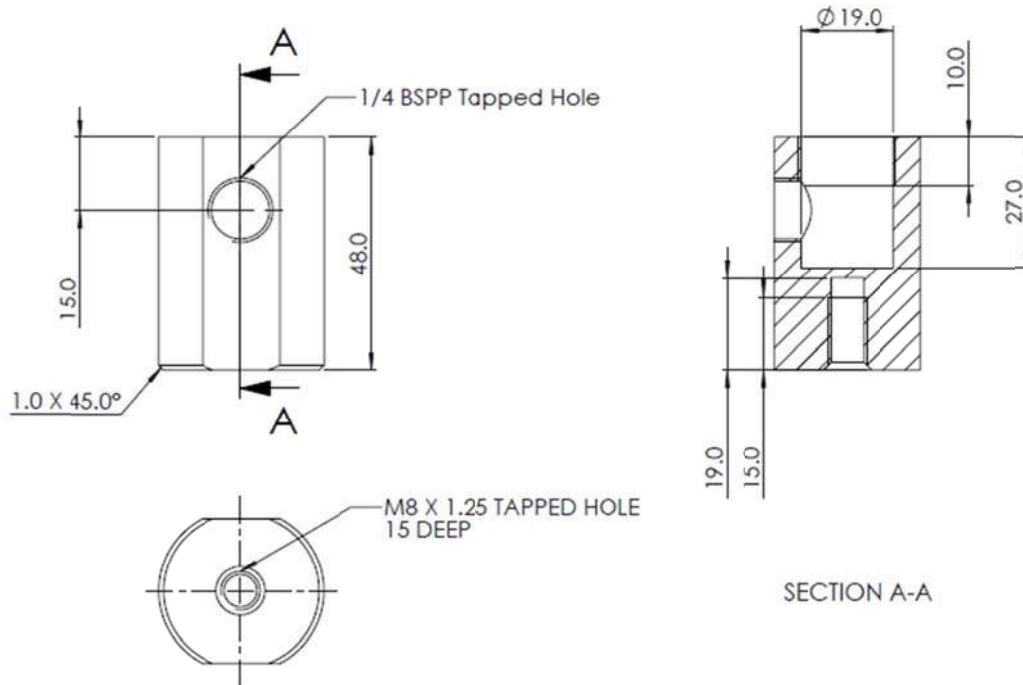

Mounting Block

Air

Connect an 8mm airline to the air inlet mounted on the side of the mounting block. Only use oil-free, dry and filtered compressed air conforming to DIN ISO 8573 class 3 or better.

Max. oil content: 1mg/m³

Max. residual dust content: particle size 5um, particle concentration 5 mg/m³

Max. residual water content: 0.88 g/m³, pressure dewpoint: -20°C

Compressed air hoses should be kept as short as possible. Kinks and bends less than 3x hose diameter should be avoided. Un-necessary quick-lock couplings in the air hose should be avoided to minimise pressure loss.

If the operating pressure is less than the permitted range, the nozzles may not rotate or will rotate slowly, but will not be damaged.

Exceeding the maximum pressure will damage the nozzle.

Connecting to Power Unit

Ensure power is turned off nor not connected to power unit before installation.

Do not touch the white insulators - high voltage will track through any contamination on this insulator and could cause a breakdown.



HP50 Power Units:



HP Connector - IMPORTANT Keep white insulator clean.
Dirt or finger grease on the white insulator can cause tracking of the high voltage and failure of the Power unit.

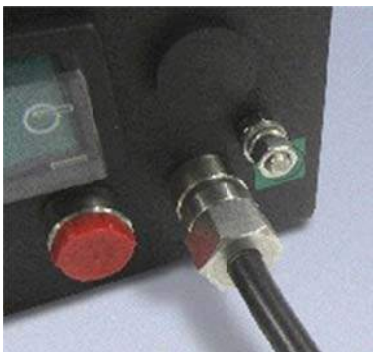

earth

Completely screw into one of ports.

- Turn the hexagon head finger tight.
- The spring contacts the internal HV source.
- Connect the earth terminal to an independent

for additional protection.

9055-2, 9050-2 Power Units:



9055-2 Connector.

IMPORTANT Keep white insulator clean!



Push connector into one port. Screw finger tight.



Connect the earth wire securely to earth stud on case.
Use the 'P' clip as a strain relief for cable if there is a risk of the cable being pulled.

When the installation has been made as the instructions in this booklet, the system is ready to turn on.

The ionised air corona produced by the emission of high voltage from the emitter pins will neutralise static charge that passes through it. This is a powerful and safe process. The emission can produce a soft buzzing sound which is not usually audible in a factory.

Ozone

The emission also produces a small amount of ozone which may be detectable by a sensitive nose. This ozone level is considerably below the international safety limit of 0.1 ppm. If the smell is undesirable then increase the level of ventilation.

Dust and Contamination

The electric field produced by the emission may attract dust from the atmosphere. It can also cause a blackening of the plastic extrusion due to carbonisation. Both the dust attraction and carbonisation are normal. See Maintenance for cleaning of Bar.

Interlock with Process

Although the equipment is designed for continuous operation, we recommend that its operation is linked with the running of the machine or process, so that the system is not running when it is not needed. This will reduce dust attraction and so reduce maintenance.

Shockless

The emitter pins are resistively coupled to the high voltage. The resistance is 100M Ohm which results in a pin energy level of about 50 μ A which is shockless. Please note that if more than one emitter is touched at the same time then the resistors may be connected in parallel and so less shockless.

Sharp Emitters

Please note that the emitter pins are designed to be sharp! They could cut fingers if handled without care

6. Maintenance

We recommend checking installation and operation regularly, at least every 4 weeks.

Important: Turn off power and air supply before cleaning or maintenance operations.



Rotating Nozzle

When installed and used as intended, the rotating nozzle is maintenance-free.

The main body and nozzles can become outwardly contaminated and should be cleaned with a soft brush and compressed air.

The rotating nozzle is manufactured using special bearings, with a very long service life. As a moving part, these bearings will wear over time. The nozzle RPM may change slightly as a result. If the RPM changes drastically, or the rotating nozzle stops working, then the unit must be serviced or replaced.

Ring Bar

Accumulation of dust and other contaminants is normal, but this will reduce the performance of the Bar. It is important to clean the Bar to keep it working efficiently.

Light dust can be removed with a nylon brush - such as a toothbrush or nailbrush.

Engrained dirt and carbonisation can be removed with IPA (isopropanol alcohol) or a similar solvent which is compatible with ABS, epoxy resin and aluminium. Soapy water can also be used.

Important: Do not turn on power until the Bar is dry. Take care - the emitter pins are sharp!



7. Troubleshooting

Poor Static Elimination

Check positioning of the Bar. It will not work well unless there is 'free' air on the opposite side of material.

Clean the Bar. Dirt around the emitters could severely affect performance.

Is the Bar Working?

Check with an electrician's 'volt stick' (it will illuminate from 200mm), or a 720 Static Bar Checker.



Try to draw a small spark to earth from the emitters, using an insulated cable with exposed conductors, or similar.

If it is a multi-bar system disconnect one Bar at a time from Power Unit and see if the system re-starts. The reason for this is that there could be a short in one of the Bars which pulls down the Power Unit by drawing more than 5mA of current. If this load is removed the rest of the system will restart.

If the Bar is not working it should be returned to the factory for further inspection or replacement if under warranty. There are no user-repairable parts in the Bar or cable.

Not rotating?

If air is coming out of the nozzles, but it is not rotating, check air pressure, otherwise contact your distributor or the factory.

8. Warranty

The warranty is for a period of 12 months from date of delivery note. It covers defective workmanship and parts provided:

- The equipment has been used within the operating conditions specified in this document.
- There has been no physical damage to the product.
- The product has not been altered or tampered with.
- The rotating jets must not have been opened or manipulated by the customer.
- The complete unit is sent back to the factory by the customer. The customer is responsible for these carriage costs, Fraser is responsible for returning the product repaired or replaced under warranty.

9. Certification and Declaration of Conformity

We declare that this equipment conforms to the following EC Directives:

Low Voltage Directive: 2014/35/EU

EMC Directive: 2014/30/EU

RoHS Directive: 2011/65/EU

Therefore CE Marking applied.

For further instructions, information or advice, please contact us or your distributor.

10.Spare Parts

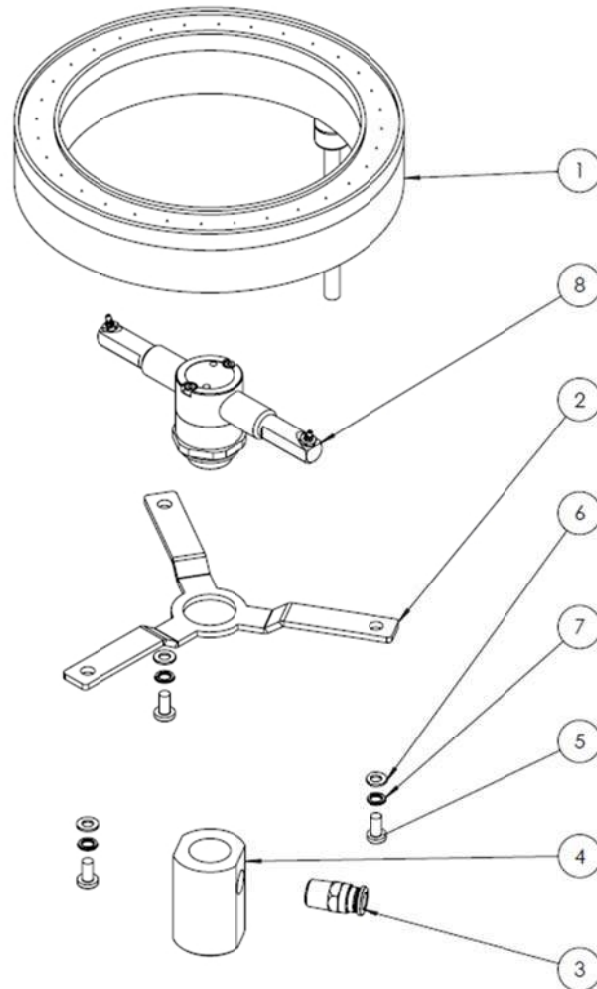

Item	Code	Description
1	12800 12802	4900-112mm Ring Bar 4900-178mm Ring Bar HV cable length specified at order (m)
2	128005 12800	112mm Bracket 178mm Bracket
3	153005	Air Fitting QS ¼-8
4	128006	Mounting Block
5	ISO7045	M5 x 10 – Z – 10N
6	80785	M5 Plain Washer
7	80733	M5 Spring Washer
8	49112 49178	112mm Nozzle 178mm Nozzle

HP connector set



For assembly by the customer. Part 90100

9055-2 Connector Set



Part 90101



HP-ILC cable Extension with 2m cable For HP connectors (not 9055-2).

Part HVC-2



Power Units

Please see range of Power Units on our website.

For more information about static and to view the full range of our products, please visit www.fraser-antistatic.co.uk

For more information about static and to view the full range of our products, please visit www.staticclean.com



Static Clean International
267 Boston Road, Suite #8
North Billerica, MA 01862
(877) 782-8423
techsales@staticclean.com

AirgunsOI_iss.2