

Instruction Manual

Fan type ionizer [WINSTAT Model BF-OHP3B]

Thank you for purchasing the WINSTAT BF-OHP3B 3-Fan type Static Eliminator. Please read this manual before using the product in order to fully understand its functions. Also make sure to store this manual so that it can be referred to in the future.

Warning

- This Product is not specified as an Explosion-proof Type. Do not use this unit at a location or an atmosphere, in which combustible gas or solvent is handled, or else ignition or explosion may occur.

High Voltage

- A high voltage is applied to the discharge needle. Do not allow any conductive material, including your finger, any part of your body, wire or any tool to get close to the needle, or an electrical shock accident or a malfunction of the Unit may occur.

1. Safety Precautions

Installation

- Install the product in a location where the power indicator and output signals can be easily checked.
- This product emits ozone into an atmosphere. Do not use this product in an enclosed space.
- Do not install the product in any of the following locations, as doing so may cause fire or electrocution.
 - Locations subject to high temperature, or high or low humidity
 - Dusty locations
 - Locations where the air inlet of the fan will be blocked
 - Locations where the product may be exposed to organic solvents such as thinner
 - Locations subject to condensation
 - Locations where the product may be exposed to corrosive gas
 - Locations subject to flames or explosions
 - Locations subject to frequent vibrations
 - Locations subject to sudden changes in temperature or humidity
 - Locations where the product may be exposed to water or oil

Power Supply

- Make sure to grasp the plug when removing the power cord. Pulling the power cord by the cord may cause it to break, or become damaged and have its core be exposed, which may cause a short circuit, or current leakage and electrocution.
- Make sure to insert the power cord firmly into the power socket. Failure to fully insert the power cord into the socket may cause fire or electrocution.
- Do not insert or remove the power cord with wet hands. Doing so may cause electrocution.
- Do not step on the power cord or place heavy objects on it. Doing so may cause damage to the cord.
- Make sure to use the power cord included with the product. (INPUT: 100V to 240V 50/60 Hz)

Maintenance

- Periodically remove the power cord and wipe any dust on the power socket away with a dry cloth. If you leave the power cord inserted in the power socket for a long period in a location with high humidity, dust, or oil, the dust will absorb the humidity, etc., which may result in a short circuit, and cause a fire.
- Make sure to turn the power of the product OFF before removing the power cord for cleaning.
- Use water (or a neutral detergent) when cleaning the filter or front louver. Also, add IPA(isopropyl alcohol) to the cloth when cleaning the discharge needles. Make sure the IPA has dried before re-inserting the power cord.

Handling

- Do not disassemble or modify the product.
- The product may affect medical devices such as hearing aids or pacemakers.
- Take care when using the product, as its internal parts are subject to high voltage.
- Do not insert any foreign objects into the product. Doing so may result in a short circuit or current leakage, and cause fire or electrocution.
- Make sure to connect the earth wire to an appropriate place. Forgetting to connect the earth wire, or connecting the earth wire to an inappropriate place may cause electrocution.
- For safety purposes, remove the power cable if you plan on not using the product for an extended period of time.
- If the product emits any abnormal odors or sounds, smoke, or heat, turn OFF the main power immediately, remove the power cord, and contact your point of purchase. Failure to do so may result in fire or a short circuit.
- Do not directly touch the discharge needles with your hands.
- Do not remove name plates or labels.
- Do not do anything with the product that is not described in this manual.

2. Outline

- This product uses a fan to blow air ionized with the corona discharge of an electrode to eliminate the static electricity in electrically charged materials that are located at a distance.
- This product is an overhead type requires no desk space, and can neutralize electricity over a large area.
- HDC-AC corona discharge system enables a balanced amount of positive and negative ions to be released for high neutralization performance. The performance of the product also deteriorates little with age, making it low maintenance.
- The high voltage output of the product are monitored and displayed on a monitor panel.
- The front louver can be easily removed/attached for easy electrode maintenance. This product also includes a safe circuit design that ensures that the high voltage output and fan stop when the louver is removed.

3. Specifications

List of Specifications

Model No.	BF-OHP3B
Input voltage	100 V to 240V AC, 50/60Hz
Power consumption	42VA max
Fuse	1 A
High voltage output	± 7,500 V o-p approx.
Ion balance (NOTE1)	± 10 V or less
Static charge removal time (NOTE1)	2.5 sec. approx.
Display LED	Power: Green / High voltage alarm: Red
Airflow	Low speed: 93cfm x 3fan High speed: 142cfm x 3fan
Quantity of produced ozone	0.005 ppm or less(at the center of the fan outlet [150 mm])
Ambient temperature	0 to 40°C (32-104°F)
Ambient humidity	15 to 85% (No condensation allowed)
Dimensions: (mm)	40"W×2.4"H×6"D (Main unit only)
Weight	11 lbs approx. (including stand)
Filter	Prefilter class
Accessories	Instruction manual (this document), Power cord, Cleaning brush

Note1: Typical value at a distance of 450 mm from the center of the each fan outlet, at maximum flow rate. (before shipment)

Appearance

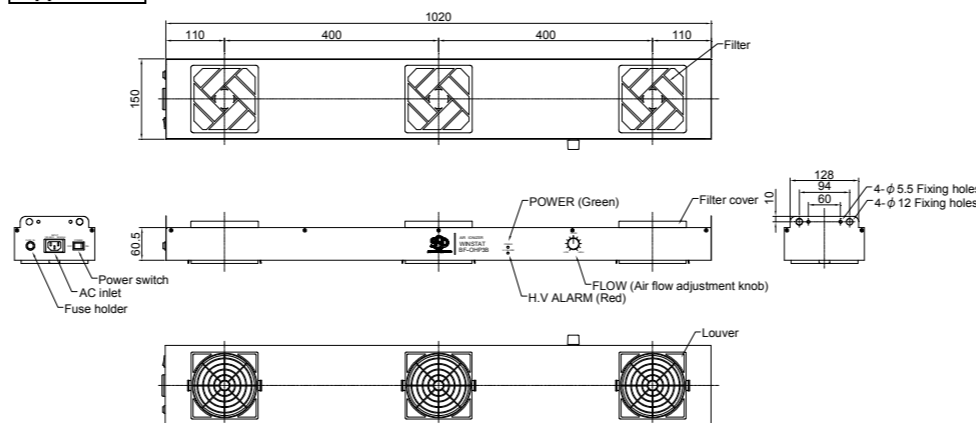

4. Installation

- Make sure to turn the power of the product OFF before removing the power cord for installing the product.

- Using the fixing holes on both sides of the main unit, suspend it from the ceiling with a chain. Alternatively, using brackets, it is possible to install this product in a variety of ways, such as on a shelf, vertically, or as a standing type.

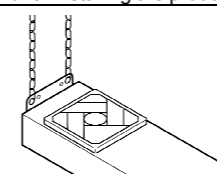

Note1: Install this device such that air flow is not obstructed.

5. Wiring

- Connect the power cord to main unit and insert the plug into an alternating current (AC 100 to 240V) power outlet.
- *This product is available with input voltage of AC100V - 240V. However, an attached power cord is available with input voltage of AC100V only (less than AC125V). If you use this product with input voltage of AC125V higher, prepare another power cord which suited to input voltage.**
- When connecting to a grounded power outlet, use the 3-pin plug. When connecting to an ungrounded (2-pin) power outlet using the adapter included with the product, be sure to ground the earth terminal. If it is not securely grounded, the product may not be able to work up to the fullest performance.

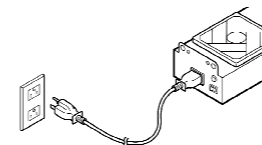

6. Operation

- Turn the power switch of the product ON, and green POWER LED becomes light up. The electrode becomes charged with high voltage, releases corona discharge, and generates neutralizing ions. At the same time, the fans spin, and blow neutralizing air from the front of the main unit. Charged materials placed in the neutralizing air will be immediately neutralized.
- The flow of the neutralizing air can be adjusted using the air flow adjustment knob.
- The operating status is displayed on the front monitor panel. If there is a high voltage output irregularity, the red H.V ALARM LED lights up.
- Turn the power switch OFF to stop the products.

7. Maintenance

- Before care and maintenance of the product, make sure to turn the power of the product OFF before removing the power cord. Otherwise accidents or operating problems may occur.
- The tip of the discharge needle is sharp, be careful not to touch the discharge needle.
- When the product is used for long periods of time, the discharge needle and the air inlet/ outlet section will get dirty. Clean the discharge needle and the air inlet/ outlet section regularly, otherwise you could not get the desired effect, and accidents and operating problems may occur.
- The maintenance required depends on the environment of use. As a reference, cleaning both the discharge needle unit and fan filter should be done once 3,000 hours.
- The discharge needle is a part having a product life time. If the charge removal performance is not restored after cleaning the discharge needle, it is recommended to replace the entire discharge needle unit with a new one. The expected life span is seemed to be 20,000 hours In case of natural wear and use.
- If you use the discharge needle unit or fan filter for replacement mentioned, please purchase below.
 - DNU-W85 : Discharge needle unit
 - OBF-FZZA-1-10 : Fan filter (10 pcs.)

Cleaning the Front Louver

- Push in the tabs on both sides of the front louver, and pull it towards yourself to remove it from the main unit. Clean the louver using the included cleaning brush. If the louver is extremely dirty, wash it with water (or a neutral detergent).
- Re-attach the front louver to the main unit after drying it thoroughly.

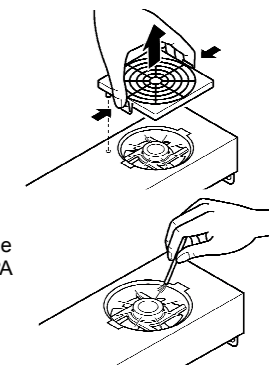

Cleaning the Discharge needles

- Remove the front louver.
- Clean the discharge needles using the included cleaning brush. If the discharge needles are extremely dirty, it is recommended you add IPA (isopropyl alcohol) to the cleaning brush.

Replacing the Discharge needle unit

- Remove the power cord and move the main unit to the horizontal place.
- Remove the front louver.
- While securely holding down the Main Unit in place, remove the Discharge Needle Unit by gripping the Finger Grip at the center of the Discharge Needle Unit and turning it in the direction of FREE (clockwise), and releasing the Unit.

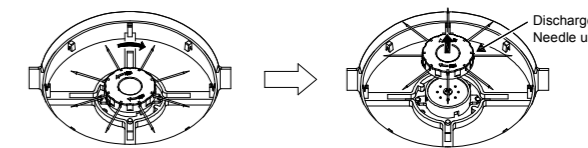

- Prepare a new set of discharge needle unit.
- Align the protrusion on the Main Unit in the section to be engaged with the discharge needle unit with the engaging section on the discharge needle unit. Press the discharge needle unit into the Main Unit, so that both units will be engaged with each other. Turn the discharge needle unit in the LOCK direction (counterclockwise) until the discharge needle unit is securely locked with the Main Unit.

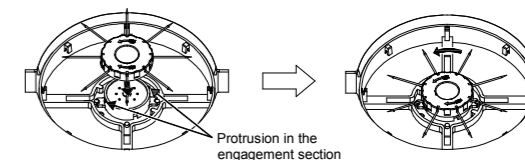

Note1: Turn the discharge needle unit until securely locked. The correct installation of the discharge needle unit on the Main Unit is essential for the optimum operation of the Product.

Cleaning the Filter

- Check that the power is turned OFF.
- While securely holding down the main unit in position, remove the filter cover. The filter cover may be easily removed by gripping the side of the filter cover and pulling it.
- Clean the soiled or clogged the filter. If the filter is extremely dirty, wash it with water (or a neutral detergent), and drying it thoroughly.
- Re-attach the filter to the main unit.

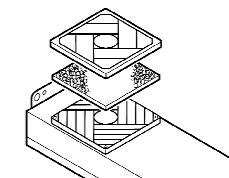

8. Troubleshooting

Problem	Main case	Remedy
The power cannot be supplied to the product.	Power cord not connected	Check to see if the AC plug is securely inserted into the product and the wall outlet.
	Louver not installed	Check the Louver to confirm that it is correctly installed.
H.V. ALARM LED (red LED) lights up.	Abnormal discharge	Check that the discharge needle is free from conductive materials. Clean the discharge needle. But H.V. ALARM LED remains light even after the discharge needle has been cleaned, clean the area around the needle is dirty.
		Check that the discharge needle unit to confirm that it is correctly installed.
	Internal circuit is broken	Turn off the power, and then turn the power back on.

Letter of Guarantee

- This product has passed the inspection carried out by our company. This product will be subject to repair or replacement, free of charge, of any failed or broken part, if a failure or a breakage should occur during the guarantee period under the condition of normal use, caused by a defect in the design or manufacture by our company.
- The Period of Guarantee: One (1) year starting from the date of delivery.
- Any repair work or replacement for any failure or breakage caused by any of the following reasons will be carried out by the user bearing the cost:
 - Any failure or breakage caused by usage or storage not under the normal condition.
 - Any failure or breakage caused by an unauthorized repair or a modification carried out by other person than our company, or not in accordance with the specifications provided by our company.
 - Any failure or breakage caused by a disaster or force majeure such as fire, natural calamity, or an act of God.
 - Any failure or breakage caused by any other reason that cannot be attributable to our company.

Product Name	Air Ionizer (Fan type Ionizer)	Model Name	WINSTAT model BF-OHP3B
Serial Number		Date of Delivery	Inspection Seal

