



HS4203 & LR4203
WITH INTEGRATED REMOTE MONITOR



Contents	Page
1 Introduction	4
2 Safety	5
3 Use	6
4 Checking on Delivered Equipment	6
5 General Specification and Dimensions	7
6 Positioning	8
7 Operation & Control	11
8 Maintenance	15
9 Health & Safety	15
10 Certification and EU Declaration of Conformity	15
11 Troubleshooting	16
12 Spare Parts & Accessories	17

1. Introduction

This manual applies to the HS4203 & LR4203 Static Eliminator Bars.

It is essential that you read and understand the complete manual before installing and using this equipment. This is important for safety and for warranty cover.

1.1 Explanation of Symbols

Warning!

This symbol appearing in the operating instructions refers to operations which, if carried out improperly, may result in serious personal injuries.



Caution!

This symbol appearing in the operating instructions refers to operations which, if carried out improperly, may result in damage to property.



2. Safety

Warnings:

- The Anti-Static Bar is only designed for neutralizing surfaces with an electrostatic charge.
- Electrical installation must only be carried out by a qualified electrical engineer.
- Adequate installation earth / ground is required to ensure safe and proper operation.
- The 0V output of the 24VDC electrical supply must be earthed.
- Disconnect the power supply before cleaning or handling the Bar.
- The emitters are sharp and can cause physical injury.
- There are no user serviceable parts inside the Bar.
- When installed correctly the ozone generated by this product is within internationally accepted limits.
- Ensure the Bar and connecting cable are free from damage prior to installation and check periodically once in use.



Any changes to the equipment without written consent of the manufacturer will nullify the warranty and CE/UL certification.

3. Use

The HS4203 & LR4203 are high performance Static Eliminator Bars. Powered by 24V DC, they have an integrated HV supply and feature remote monitoring to check bar function remotely.

They are designed for internal factory use.

HS4203 (HS = High Speed)

Designed to cope with speeds up to 4264 ft/min. Ideal for fast moving materials.

Operating distance for best performance 25-100mm (1"-4").

LR4203 (LR = Long Range)

Designed to cope with distances from 100-500mm (4" - 20").

Designed for applications with changing geometry.

4. Checking on Delivered Equipment

The equipment leaves our factory in suitable protective packaging. Please check that it is undamaged when it arrives. If there is visible damage contact the Factory or one of our Distributors immediately, before carrying out any installation.

Check that the parts that which have been delivered are the same as you have ordered.

Loose Parts: Mounting 'T' nuts with nylon bolt - 2 for the lengths up to 1m (39") plus extra mounting bracket for every additional 1m (39").
M8 Connector and lead - as per order.

5. General Specification and Dimensions

Power Supply:	Voltage: 24V DC (21-28V). Current: 0.5A DC max when used without the Remote Monitor. Up to 1A DC max when using the Remote Monitor.
High Voltage:	9kV integrated into Bar.
Supply cable:	Low voltage, industry standard M8 connector 4-pin.
Emitters:	Long life high grade Tungsten.
Status indication:	LED. Green = OK. Red = fault or very dirty Bar. Remote Monitor - see page 12-13
Environmental:	IP66. Internal use. 0-55°C / 32-131° F Max. Dry: max 70% rH, non condensing.
Length:	Effective length = 100% of actual length.
Height and Width:	Height = 41.5mm (1.6"). Width = 22mm (.86").
Weight:	1.1 kg/m.
Mounting:	Low profile mounting blocks within the Bar.
Approvals:	CE, UL and CB.

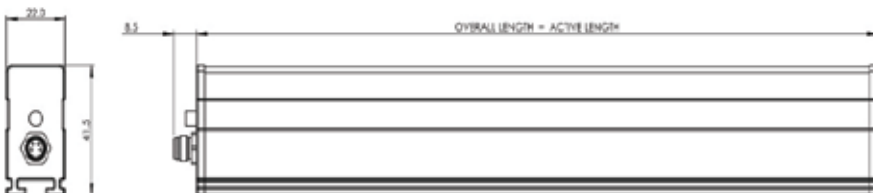

6. Positioning

- i. The best location is at, or immediately before, the area where static is causing the problem. Remember that static can be regenerated if the material passes over rollers or through a process after neutralizing. A Static Meter is useful to determine the best position.
- ii. **Important.** Except on a winding reel of material, the material to be neutralized should be in free air, not touching another surface as it passes the Bar. It is not possible to neutralize static electricity where the material is touching another surface or roller. Position the Bar 50mm (2") from rollers or the machine frame.

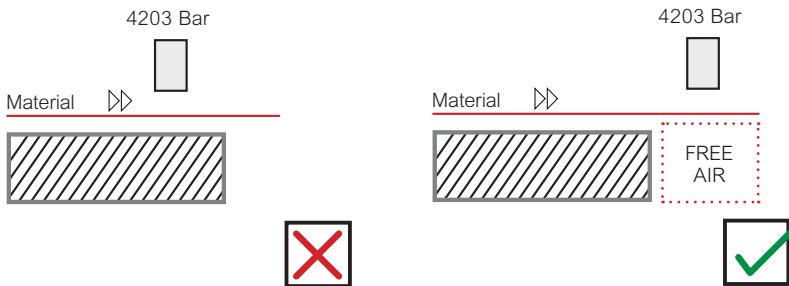

- iii. The emitter pins should face the material to be neutralized and be within the following operating distance:

HS4203: Operating distance 25-100mm (1-4").

LR4203: Operating distance 100-500mm (4-20").

- iv. The bars must be dry and oil-free.
- vi. It is important that the emitter pins are not touching, or close to metal objects, to avoid spark erosion that will damage both the Bar and the metal object.
- vi. If more than one Bar is used, they should not be positioned directly opposite each other, but should be offset by at least 50mm (2").



6. Positioning

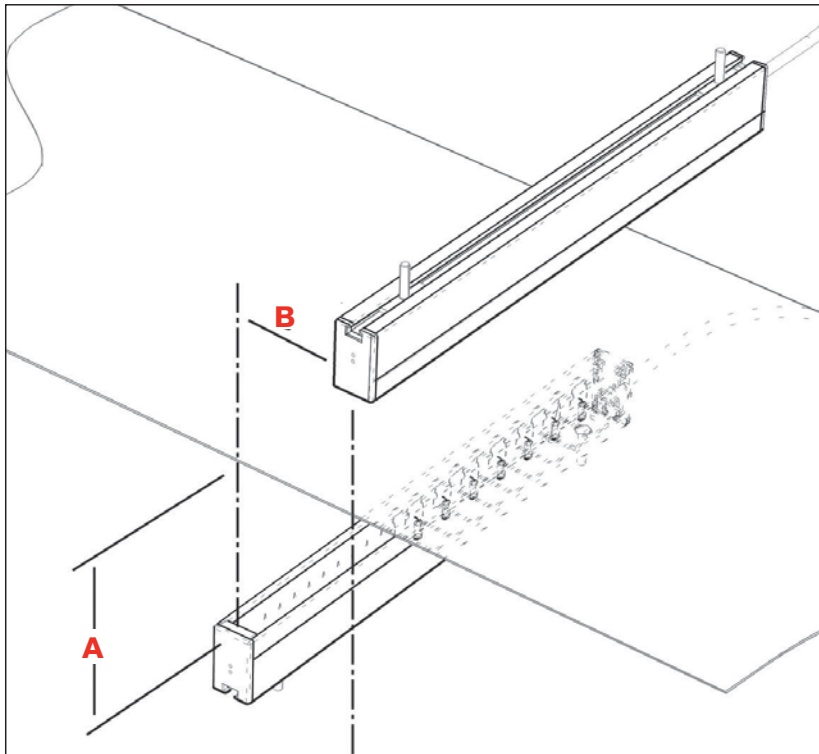

- Emitters facing material.
- Bar >50mm (2") from rollers or machine parts.
- Material in free air (optimum).
- Distance "A": depends on Bar type. Closer is better.
- Distance "B": if there are two Bars, offset them >50mm (2")

6. Positioning

HS4203

- Distance from material: 25-100mm (1-4"). Best distance 25-70mm (1.0-2.75"). Do not position the HS4203 closer than 25mm to the material.
- Material should be in free air.
- With a plastic DC Bar like the the HS4203 the nearest earth should be more than the distance of the product. If there is an earthed body closer to the Bar than the material to be neutralized it will attract the ions from the Bar. So if the Bar is 50mm (2") from the material to be neutralized there should be no metal and earthed parts closer than this.

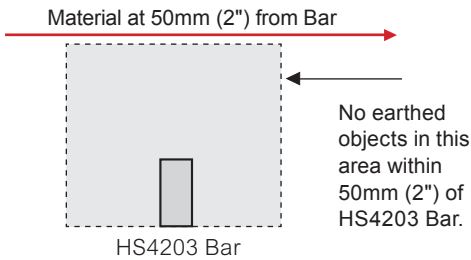

LR4203

- Distance from material: 100-500mm (4-20"). Best distance 100-300mm (4-12").
- General installation considerations are the same as HS4203.

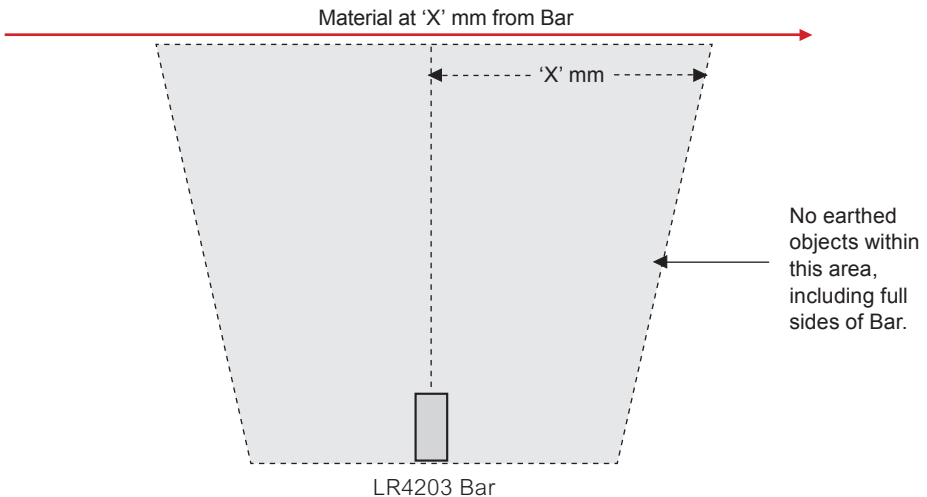

7. Operation & Control

Warning: Failure to follow the installation requirements may result in injury or damage to equipment.

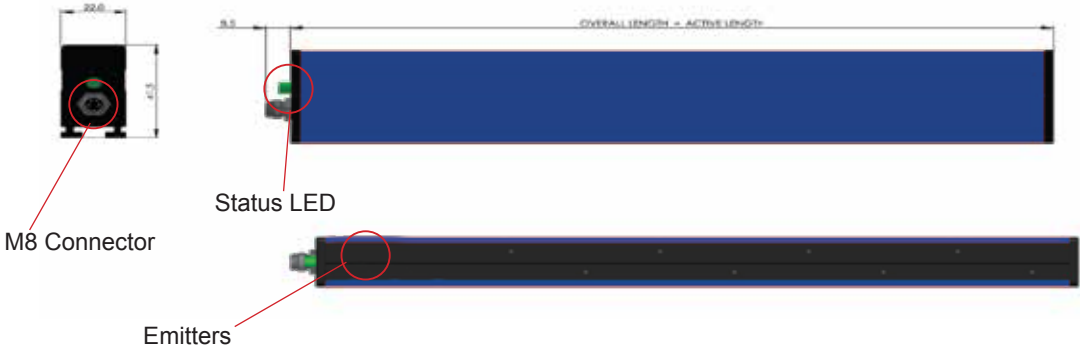

1. Electrical

Using an existing 24V DC supply:

The 24V output must be fitted with a 1 Amp fuse e.g. Type : 1AT 250V

The 0V output must be connected to earth.

The WHITE wire to the M8 4-pin connector must be connected to installation earth.

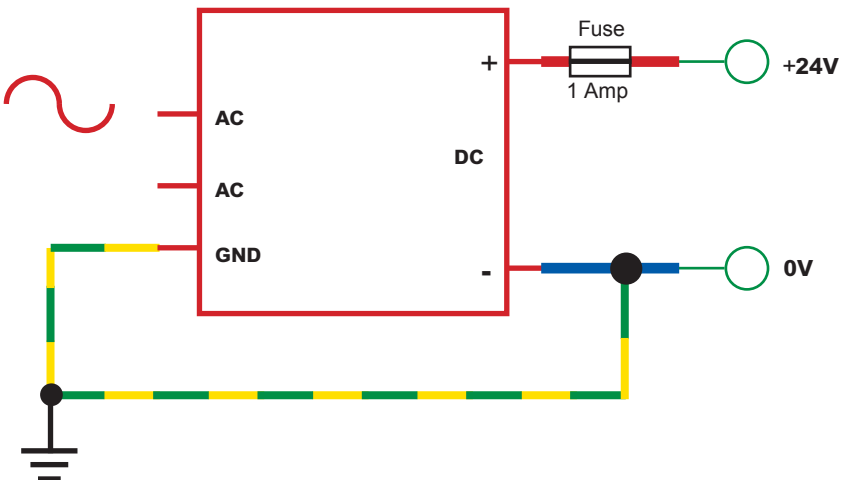

7. Operation & Control

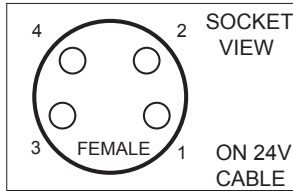
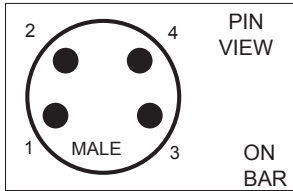

Pin	Colour	Function
1	Brown	24V
2	White	Earth
3	Blue	0V & Earth
4	Black	Remote Monitor

2. Status LED and Remote Monitor

The 4203 Bar gives a signal showing its operational status in two ways:-

i. LED

- the LED mounted above the cable connector on the Bar
- flashes GREEN if all is OK.
- flashes RED if there is a fault.

ii. Remote Monitor

- uses the black wire in the 4 wire supply cable to send a 0V or 21-28V signal to the PLC or other destination chosen by the customer.
- the voltage is taken from the power supply to the Bar. No additional power source is required. The voltage out will be the same as the voltage in: 21-28 V DC.

See wiring diagram and examples below.

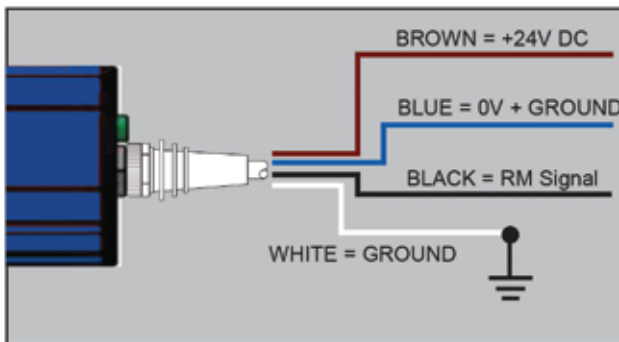

If remote monitor function is not needed insulate black wire and do not connect anything to it.

7. Operation & Control

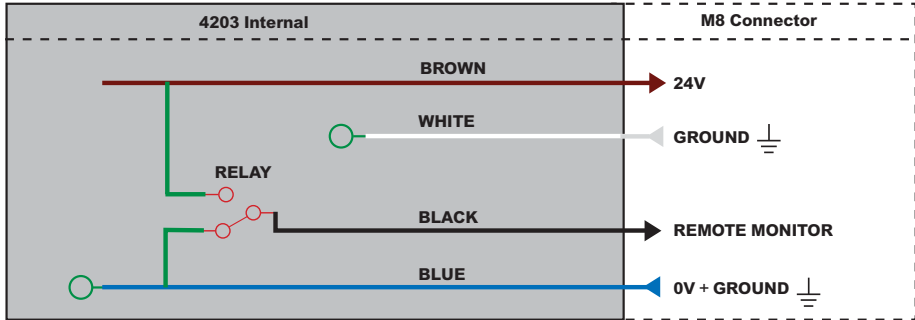

Remote Monitor signal is valid 4 seconds after power is applied.

BLACK = 24V when 4203 status signal **OK**

BLACK = 0V when 4203 status signal **FAULT**

Example Application Use of Remote Monitor

EXTERNAL LAMP/INDICATOR

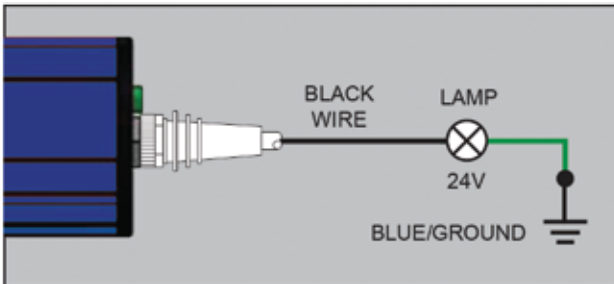

External indicator can be connected to BLACK wire to show status. This is useful for bars mounted in inaccessible areas.

Lamp rating 24V DC, maximum 10W. A LED can also be used with a suitable resistor. Maximum current 0.5Amp.

EXTERNAL RELAY

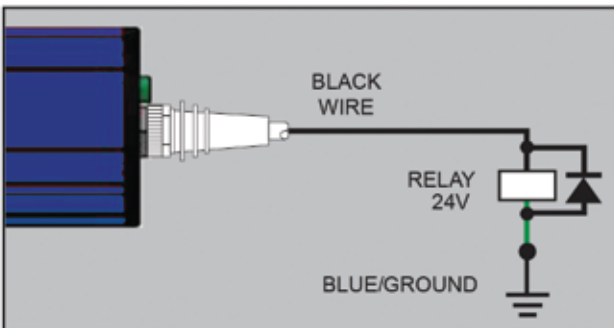

External relay can be connected for additional control/feedback configurations.

Coil rating 24V DC, 10W max.

7. Operation & Control

Faults

A fault signal could mean:-

- i. Input voltage is outside of 21V - 28V range.**
 - check input voltage at Bar.
- ii. Bar overloaded.**
 - clean Bar.
 - make sure that positioning of Bar meets these instructions.
- iii. H.V. output not correct.**
 - contact Static Clean or distributor.

Where the optional 90-264V AC Power Supply has been ordered ensure the Power Unit is connected to 3 wire AC mains supply. Live + Neutral + Ground, and that extra Earth wire from power supply is bonded to Ground. With this optional supply an interface cable is required to access the remote monitor feature.

3. Mechanical

1) Mounting Brackets

Versatile mounting block (T-nut) with hex bolt and hex nut slide into the slot at the back of the bar.

Important Note: “DO NOT BOTTOM-OUT THE HEX BOLT AGAINST THE BACK OF THE BAR.”

Two mounting blocks for bars up to 1m (39"), plus extra mounting brackets for each additional 1m (39").

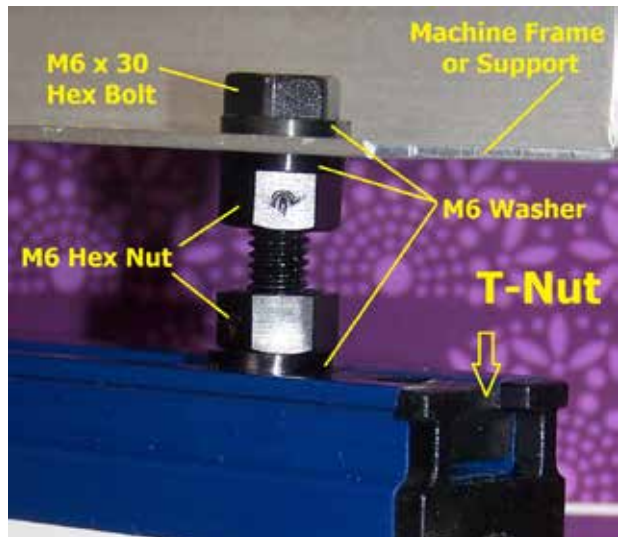

8. Maintenance

Turn off electricity to the Power Unit before doing any installation or maintenance work.



Cleaning is the only maintenance required. Dirt around the emitters will reduce efficiency and result in unsatisfactory performance. A toothbrush or nail brush is ideal for cleaning Bars. Do not use a wire brush as this could damage the Bar. The Bar can be washed with soapy water or IPA, but it must be dry on the inside of the Bar around the emitters before turning the power on.

When cleaning around the emitters **-take care as the pins are sharp!**

9. Health and Safety

When installed correctly the ozone generated by this product is less than 0.1ppm and within internationally accepted limits.

Please note, when handling and cleaning, that the emitter pins are sharp and care is needed.

The emitter pins are shockless - there is a large resistor below each emitter reducing the current to a shockless level. However please note that D.C. current can transfer charge to a body if it is touching or close to an emitter for a longer period. This could give a shock when discharging.



10. Certification and CE Declaration of Conformity

We declare that this equipment conforms to the following EC Directives:

Low Voltage Directive: 2006/95/EC.

EMC Directive: 2004/108/EC

And is entitled to display the CE Mark.

For further instructions and information, please contact the manufacturer.

11. Troubleshooting

On power-up, the status LED will be RED for up to 3 seconds while internal checks are being carried out inside the bar. After this time, if all operating conditions are normal, the status LED will turn GREEN.

If the status LED does not illuminate GREEN or RED, then check the electrical supply. If the electrical supply is OK, then check the connecting cables for damage.

If the status LED is RED, then this indicates overload or other fault:

- Turn the power off and clean the bar.
- Check the electrical supply.
- Check the installation location is as described in this manual.

12. Spare Parts & Accessories

Item Picture	Description	Part No.
	<p>3m cable M8 female, bare ends. Straight socket.</p>	<p>4203-80892</p>
	<p>5m cable M8 female, bare ends. Straight socket.</p>	<p>4203-80930</p>
	<p>7.5m cable M8 female, bare ends. Straight socket.</p>	<p>4203-80931</p>
	<p>10m cable M8 female, bare ends. Straight socket.</p>	<p>4203-80932</p>
	<p>3m cable M8 female, bare ends. 90° socket.</p>	<p>4203-80933</p>
	<p>5m cable M8 female, bare ends. 90° socket.</p>	<p>4203-80934</p>

12. Spare Parts & Accessories

Item Picture	Description	Part No.
	<p>7.5m cable M8 female, bare ends. 90° socket.</p>	<p>4203-80935</p>
	<p>10m cable M8 female, bare ends. 90° socket.</p>	<p>4203-80936</p>
	<p>Universal AC/DC power supply: 100-250V AC, 24V DC output Fitted with 1.5m of cable, and M8 female</p>	<p>4203-31101</p>
	<p>M8 male to M8 female 4-pin extension cable for AC/DC power supply unit. (available in 2m lengths.)</p>	<p>4203-80937</p>
	<p>Mounting 'T' Block</p>	<p>4203-708026</p>
	<p>Mounting Bolts</p>	<p>4203-80788</p>
	<p>Mounting M6 Nylon Hex-nut</p>	<p>4203-80789</p>

For more information about static and to view the full range
of our products, please visit www.staticclean.com



Static Clean International, Inc., 15 Adams Street Burlington, MA. 01803
P: (781) 229-7799 F: (781) 229-4555
E sales@staticclean.com W www.staticclean.com
