

THE TEKNEK CM10 CLEAN MACHINE

teknek



TEKNEK CM10 CLEAN MACHINE

The CM10 Clean Machine has been specifically designed to provide double-sided cleaning of large format substrates. The wide range of applications for this machine include graphics, screen printing, LCD manufacture, lamination, packaging and glass manufacturing.

The machine uses the proven Teknek elastomer contact cleaning rollers and adhesive roll which provides the most efficient cleaning engine and yield improvement system in the market today. The four large diameter elastomer rollers will lift dry unattached particles down to 1 micron in size and then transfer these to the reverse wound pre sheeted adhesive roll. When the adhesive is full of contamination a layer is removed and the adhesive is refreshed.

SPECIFICATION

Available in three cleaning widths	1000 - 1200 - 1500mm
Process Speed Options	3 - 12m/min & 10 - 40m/min*
Mode of Operation	Uni-Directional & Auto Reverse
Conveyor Options	Refer to attached drawing information
Pass Line Height	950 +/- 50mm
Power Supply	Selectable - 100 - 230v 50/60hz
Pneumatic Pressure Required	5 - 7 Bar or Free Air

*Speeds outwith the stated figure above available through our "RFQ" Request For Quotation process



FEATURES

BENEFITS



Easy to use "Tilt system"

Unique "space saving" access to both elastomer roller and Teknek pre sheeted adhesive rolls. No need for side pull out as the "tilt system" allows complete access to the "cleaning engine".



Tape conveyors at different lengths

Modular tape conveyor design giving a complete cleaning solution to be integrated into any process.

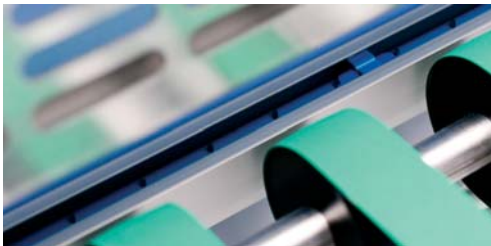

Powerful, safe 7Kv anti static system

Anti static bars on the exit of the machine, greatly reduce the risk of re-contamination of the sub strate after cleaning.

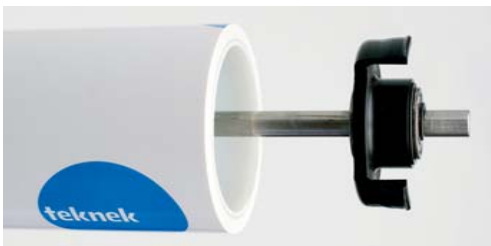

Adhesive Roll spindle system " No Tools required "

The unique spindle system allows the operator to replace the pre sheeted adhesive roll without the use of any tools.



Simple machine controls

The simple controls that feature at one end of the CM10 allow the machine to be operated with minimum operator training.



Panel count facility, optional

The optional panel count facility allows you to set the number of panels between adhesive roll refresh in relation to your process.

TEKNEK CM10 CLEAN MACHINE



TECHNICAL SPECIFICATION

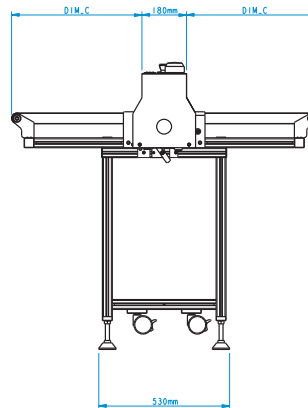
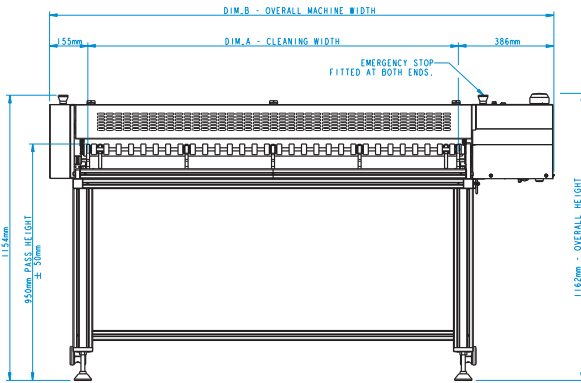

MACHINE	DIM_A	DIM_B
CM10 - 1500	1500mm	2040mm
CM10 - 1200	1219mm	1760mm
CM10 - 1000	1000mm	1540mm

CONVEYOR TYPE	DIM_C
'1500' LONG TAPE	1528mm
'1000' LONG TAPE	1028mm
'800' LONG TAPE	828mm
'500' LONG TAPE	528mm
STUBBY TAPE	286mm



Maintain the Teknek cleaning engine performance with Teknek pre-sheated adhesive rolls. Reduce operator injuries as there is no need for knives. Reduce scrap as the operator only removes one layer of adhesive at a time. [Order](http://www.teknek.com) your replacement Teknek sheeted adhesive rolls at www.teknek.com



Teknek elastomer rollers, main components within "The Teknek Cleaning Engine" are manufactured in our own production facility. Our in-house team of chemists, engineers and designers work together to ensure the elastomer rollers made are the best in the world. [Order](http://www.teknek.com) your replacement Teknek elastomer rollers at www.teknek.com

WORLD LEADER IN CONTACT CLEANING

Teknek Head Office
River Drive
Inchinnan Business Park
Renfrewshire, PA4 9RT
Scotland, UK

T: +44 (0)141 568 8100
F: +44 (0)141 568 8101

Teknek Japan Ltd
Meiji-Yasuda Seimei Building,
6-83 Onoe-cho, Nakaku
Yokohama City
Japan 231-0015

T: +81 (0)45 640 0670
F: +81 (0)45 640 0671

Teknek China Ltd
Unit G02, G/F, Myloft,
9 Hoi Wing Road,
Tuen Mun, N.T.,
Hong Kong

T: +852 2468 3160
F: +852 2462 3036